



GRIDCON<sup>®</sup> STATCOM

REACTIVE POWER COMPENSATION  
WITH MAXIMUM REGULATING  
DYNAMICS.

[WWW.REINHAUSEN.COM](http://WWW.REINHAUSEN.COM)





# GRIDCON<sup>®</sup> STATCOM: FOR OPTIMAL REACTIVE POWER CONTROL IN DISTRIBUTION NETWORKS.

Efficient network stabilization and load-flow optimization for tough requirements.

The energy market is currently undergoing significant changes in regard to the requirements for liberalizing and opening the market as well as the resulting demand for incorporating new energy resources and efficient means of regulating the flow of energy.

In addition, global climate protection requirements and the associated need for effective CO<sub>2</sub> reduction are acting as driving forces behind the conversion of traditional network structures. The goal is innovative distribution networks with dynamic load-flow regulation at a variety of levels.

As a global system integrator, Maschinenfabrik Reinhausen (MR) offers a wide spectrum of customer and application-specific solutions for successfully navigating the challenges associated with setting up and operating innovative distribution networks.

GRIDCON<sup>®</sup> STATCOM provides a high-performance platform for making this a reality. It enables efficient implementation of voltage stabilizing and load-flow optimizing measures with high requirements for regulating dynamics in both public and industrial distribution networks. GRIDCON<sup>®</sup> STATCOM systems are based on a scalable performance electronics platform with 3-level IGBT inverters, enabling innovative solution approaches for dynamic regulation tasks in distribution networks.

## Extensive customer benefits

The GRIDCON<sup>®</sup> STATCOM system architecture has been developed to optimize the transmission behavior in distribution networks with a modular solution approach, generating significant benefits for customers as a result. These include:

- Reducing operating costs by dynamically improving the power factor at the grid connection point and ensuring compliance with contractually stipulated connection conditions
- Improving grid stability by dynamically providing inductive and capacitive regulated power
- Improving voltage stability using innovative voltage regulating algorithms
- Providing operating behavior with high regulating dynamics together with low operating losses
- Ensuring low harmonic current emissions thanks to active built-in compensation
- Providing cost-effective solutions with reduced engineering and production expenses
- Providing customer and application-specific solutions through standardized and modular system architecture

# GRIDCON® STATCOM SYSTEM CONCEPT.

A coupling transformer (implemented as a 2-winding or 3-winding transformer) makes it possible to adapt the connection voltages of GRIDCON® STATCOM systems to any medium-voltage level with a high degree of flexibility.

Up to two individual STATCOM systems of up to  $\pm 3600$  kvar each can be connected over a shared three-winding transformer. This makes it possible to implement any power desired up to  $\pm 7200$  kvar in 600 kvar increments.

The controller platform also has a modular design to ensure optimal system scalability. Each system has a central control computer unit (CCU), which can be equipped with one or more remote measuring units (MIO) for measuring the network and load factors (voltage, current).

**4 x IPU = 1 x power module**  
**6 x power module = STATCOM**

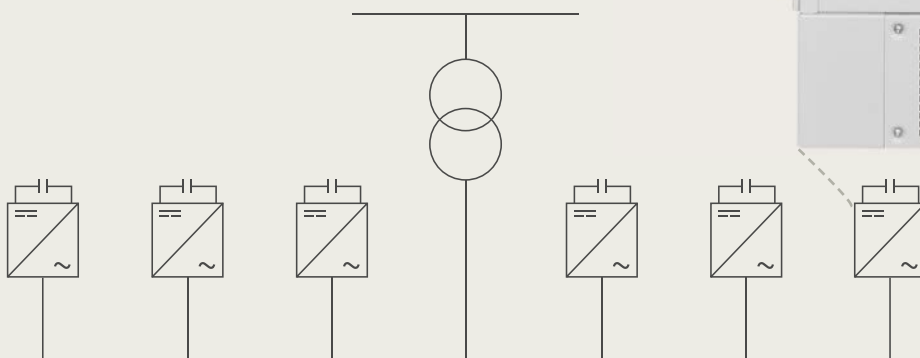

Typical overview connection diagram of a GRIDCON® STATCOM system – it contains from 1 to a maximum of 6 power modules



GRIDCON® STATCOM has a modular design. It is based on IGBT power units (IPU) with a rated current of 125 A and a rated voltage of 690 V. These are combined together in cabinets to power modules with  $\pm 600$  kvar, up to six of which can be combined into a complete system with a power of  $\pm 3600$  kvar. An integrated control cabinet unit with a circuit breaker completes the system.



Separate fan for cooling peripheral components, up to IP54 degree of protection possible

IPU IGBT unit with autonomous regulation and self-monitoring

Fan drawer for simple replacement of the main fan

Behind the connection space: Partitioned ventilation duct without any live components for IGBT main cooling; air is fed in through the base/mount

#### Overvoltage ride through

$U_{bus} = 1.10$  pu (continuous);  $U_{bus} = 1.15$  pu (maximum 30 sec + settling time)

#### Fault ride through

The GRIDCON® STATCOM system rides through faults without disconnecting from the grid.

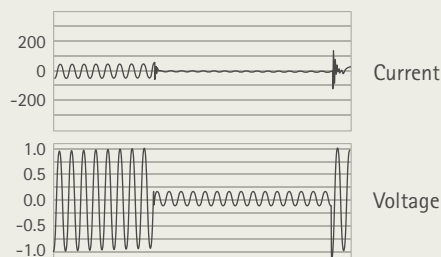

$0 \leq U_{bus} < 0.2$  pu:  $I_{statcom} = 0$  (250 ms)

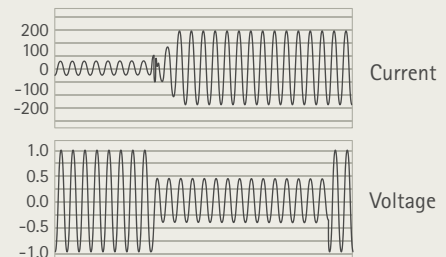

$U_{bus} > 0.2$  pu:  $I_{statcom} > 0$  continuous

# WIDE RANGE OF APPLICATIONS IN MANY INDUSTRIES.

GRIDCON® STATCOM systems make it possible to provide dynamic fundamental harmonic reactive power (capacitive and inductive) in one broad power range and adapted to the respective customer application.

## Dynamic reactive power regulation and voltage stabilization



ROLLING MILLS



OFFSHORE TECHNOLOGY



TRACTION SYSTEMS



MINING



WIND AND PV PARKS



PAPER INDUSTRY



TESTING FACILITIES



LOGISTICS

The use of GRIDCON® STATCOM systems always requires carrying out a customer-specific examination of the use case and a network study regarding the dynamic control response within the respective customer application.

With its in-house development department and an internal team of experts for power electronics applications, MR has the necessary resources to design STATCOM systems to meet specific customer needs and to integrate the systems into the respective application.

## Other applications

- Stabilizing weak system voltages
- Reducing transmission losses
- Increasing transmission capacity
- Reducing voltage fluctuations
- Improving power factor
- Reducing harmonic current
- Preventing flicker
- Stabilizing the voltage during and after faults in the grid

# READY AT ANY TIME – GRIDCON<sup>®</sup> STATCOM IN OFFSHORE OPERATIONS.

The discovered and projected gas and oil fields in the Arabian Gulf are among the world's largest fossil fuel reserves. Saudi Arabia is involved in three mega projects related to the exploitation and subsequent extraction of these resources. One of these projects is the development and implementation of the AL WASIT gas program. Saudi Aramco, the largest oil-producing company in the world, has tapped two new gas fields, HASBAH and ARABIYAH, as part of those efforts. These fields form the basis for the Al Wasit gas program as a strategic government project for increasing the amount of gas being extracted.

Economical utilization of the gas fields required the construction and commissioning of two production platforms. The gas fields with the two production platforms are located in the Arabian Gulf and supplied with submarine cable connections. Due to the length of the submarine cable connection, the resulting cable capacitance has a significant effect on the load flow between the onshore primary substation and the offshore platforms, also affecting the voltage profile as a result.

This made it necessary to find a solution for dynamic voltage control. This is where Saudi Aramco brought the professionals from MR on board. Together, the two partners developed a fitting solution in a detailed design process that took more than a year. GRIDCON<sup>®</sup> STATCOM is that solution.

Due to the fast reactive power and voltage control GRIDCON<sup>®</sup> STATCOM enables safe and stable operation of customer-specific technology on the platforms both during normal operation as well as in special operating modes (such as isolated operation).

## Modular solution concept

Thanks to the modular solution concept, the GRIDCON<sup>®</sup> STATCOM systems allow for compact installation in suitable containers. In addition, the modular solution approach provides the option of implementing redundancy requirements from the customer application and reducing service expenses. This is especially critical for applications requiring high reliability.



Short design and delivery times are another advantage of the modular approach. By using standard IGBT units in a standard panel design, the engineering efforts will be reduced significantly, which allows to process a project in a straight and lean timeline – from starting the design until plant acceptance tests.

A complete 13.8 kV laboratory grid with generation and variable load was specifically set up to test the performance capability of the GRIDCON<sup>®</sup> STATCOM systems and optimize them under realistic conditions. Simulations run in advance on the stationary and dynamic operating behavior using a real-time digital simulator (RTDS) provided the specifications for the integration test.

The systems were integrated into the platform at a shipyard in Indonesia and transferred to the destination in the Arabian Gulf where the successful offshore commissioning was carried out in June 2015.

# IMPRESSIVE TECHNOLOGY – DEPENDABLE PERFORMANCE.

## Operating states

GRIDCON® STATCOM systems are based on a voltage source converter (VSC), which is connected to the grid through an inductance and a transformer. Once the STATCOM system is operating, two distinct general operating states exist. In both cases, the grid voltage is assumed as  $U_{Grid} = \text{const}$ :

### Capacitive operation:

- Vector  $U_{Comp} > \text{Vector } U_{Grid}$  means: Vector  $U_T$  points in the same direction as Vector  $U_{Comp}$
- Current  $I_{Grid}$  flows in a positive direction (as shown in the figure)
- The STATCOM system feeds capacitive current into the network
- The voltage increases

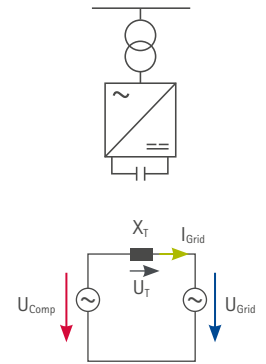

### Inductive operation

- Vector  $U_{Comp} < \text{Vector } U_{Grid}$  means: Vector  $U_T$  points in the direction opposite  $U_{Comp}$
- Current  $I_{Grid}$  flows in a negative direction (as shown in the figure)
- The STATCOM system feeds inductive current into the network
- The voltage drops

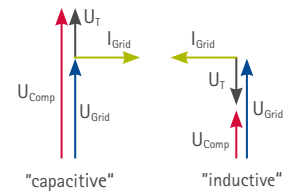

## 3-level technology

The 3-level circuit of GRIDCON® STATCOM systems is based on twelve IGBTs, whereas the conventional 2-level version only has six. The special circuitry halves the voltage loads on the power semiconductors. This leads to lower losses while also allowing use in grids with a higher intermediate circuit voltage. This also allows the generation of higher peak currents, which is required for filtering harmonics with a higher bandwidth. Another benefit of the 3-level technology is the lower ripple of the output current compared with a 2-level architecture. The divided intermediate circuit and larger number of IGBTs result in an additional third switching state at the output. This enables a more compact design for the network and EMC filters while retaining the same switching frequency, reducing losses as a result.

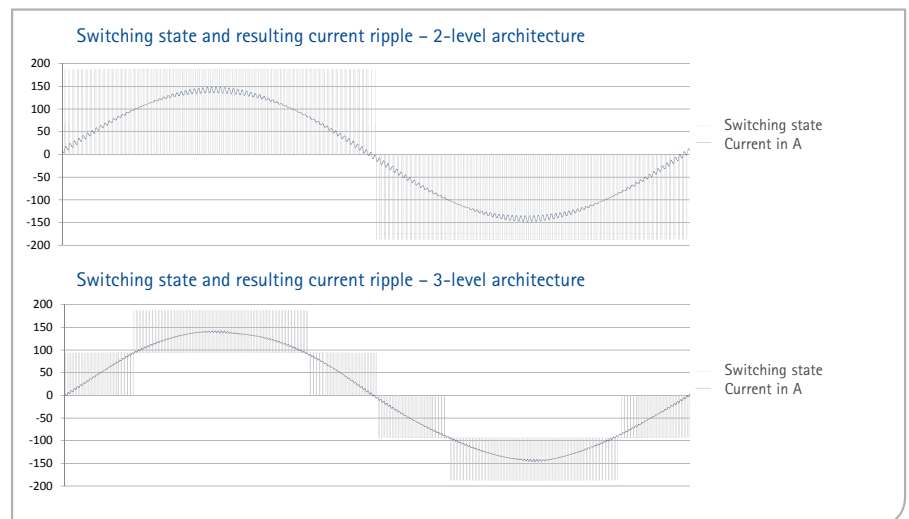
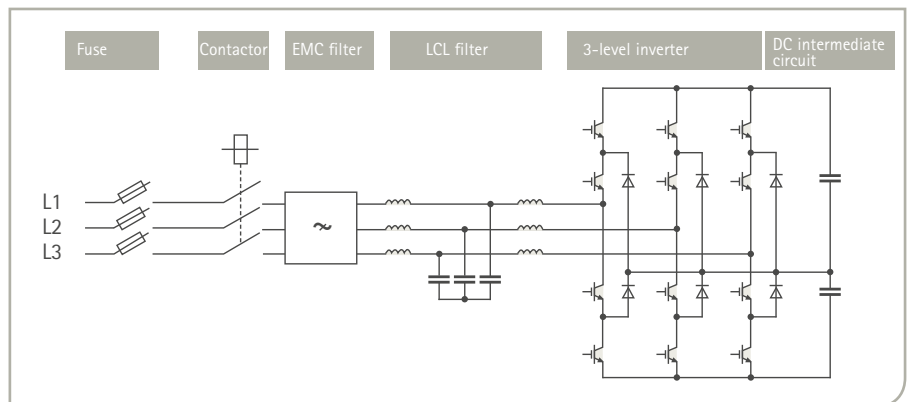



## Operating concept

### Operation

Parameterization, operation and monitoring of the overall system are handled through an industrial control system (PLC) with graphics-capable touch panel (HMI):

- Parameterization (system parameters)
- Command input for operating the system
- Visualization of the system configuration, including equipment states
- Visualization of measured values
- Display of event and error messages

In addition, an interface is provided for integrating the GRIDCON® STATCOM system into a higher-level station layer (SCADA).

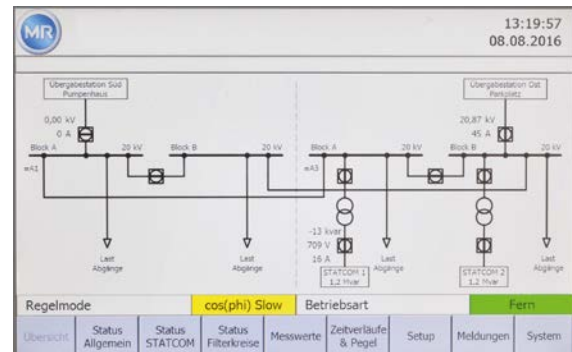

### Service

The touch panel forms the service interface of the GRIDCON® STATCOM system. This serves as an operating and display element close to the system. It features a clear menu structure that can also be used to display data in tables or charts.

The features offered by the touch panel include:

- Parameterization (hardware parameters)
- Status and error messages in plain text
- Ability to switch languages at any time
- Password protection

The GRIDCON® STATCOM system can also be operated using a web-based interface. Logs are saved on an SD card for export in the event of service.

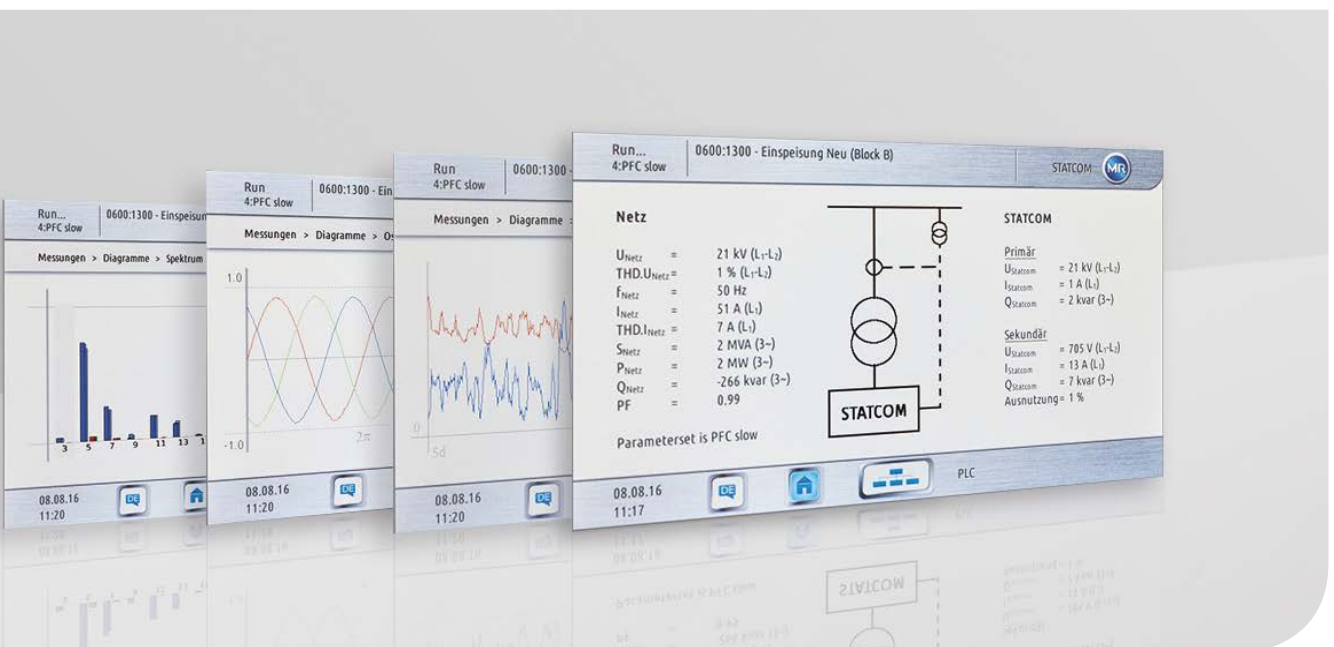

# TECHNICAL DATA.

Technical data	GRIDCON® STATCOM				
Rated voltage	3 kV - 35 kV with matching transformer				
Grid frequency	50 Hz / 60 Hz				
Regulating functions	Voltage regulation Reactive power regulation				
Additional functions	Optional ACF functionality (2nd-51st harmonic (50 Hz) / 2nd-41st harmonic (60 Hz))				
Power loss for active part	< 2.1% of the compensation maximum, < 1.8% during typical operation, < 0.4 % at idle, < 100 W in standby				
Switching frequency	10 kHz (low-loss design)				
Control	Internal control computer with two digital signal processors				
System setup and display	Using HMI with graphical display or internal web server (TCP/IP) and PC – no additional software required				
Response time	Application-dependent, typically 10 - 40 ms				
Interfaces	Ethernet (TCP/IP) Various fieldbus systems (including Profibus and Modbus) Digital I/O interface (potential-free, configurable) for status message				
Measuring transformer	Grid/load measurement: 3-phase voltage measurement 2-phase or 3-phase current measurement  STATCOM measurement: 2-phase or 3-phase current measurement				
Inverter	3-level IGBT with voltage intermediate circuit (DC film capacitors)				
Coloring	Standard: RAL 7035 light gray (other colors and designs on request)				
Dimensions (approx. W x D x H)	Power module: 800 x 800 x 2000 mm 800 x 800 x 2200 mm with optional base  STATCOM (active part) including Cable infeed				
	2 power modules	3 power modules	4 power modules	5 power modules	6 power modules
	1200 kvar	1800 kvar	2400 kvar	3000 kvar	3600 kvar
	2200x800x2000	3000x800x2000	3800x800x2000	4600x800x2000	5400x800x2000
	2400 kvar	3000 kvar	3600 kvar		
	4 power modules	5 power modules	6 power modules		
	2400 kvar	3000 kvar	3600 kvar		
	3800x800x2000	4600x800x2000	5400x800x2000		
	4 power modules	5 power modules	6 power modules		
	2400 kvar	3000 kvar	3600 kvar		
	3800x800x2000	4600x800x2000	5400x800x2000		
	4 power modules	5 power modules	6 power modules		
	2400 kvar	3000 kvar	3600 kvar		
	3800x800x2000	4600x800x2000	5400x800x2000		
	4 power modules	5 power modules	6 power modules		
	2400 kvar	3000 kvar	3600 kvar		
	3800x800x2000	4600x800x2000	5400x800x2000		
	4 power modules	5 power modules	6 power modules		
	2400 kvar	3000 kvar	3600 kvar		
	3800x800x2000	4600x800x2000	5400x800x2000		
	4 power modules	5 power modules	6 power modules		
	2400 kvar	3000 kvar	3600 kvar		
	3800x800x2000	4600x800x2000	5400x800x2000		
	4 power modules	5 power modules	6 power modules		
	2400 kvar	3000 kvar	3600 kvar		
	3800x800x2000	4600x800x2000	5400x800x2000		
	4 power modules	5 power modules	6 power modules		
	2400 kvar	3000 kvar	3600 kvar		
	3800x800x2000	4600x800x2000	5400x800x2000		
	4 power modules	5 power modules	6 power modules		
	2400 kvar	3000 kvar	3600 kvar		
	3800x800x2000	4600x800x2000	5400x800x2000		
	4 power modules	5 power modules	6 power modules		
	2400 kvar	3000 kvar	3600 kvar		
	3800x800x2000	4600x800x2000	5400x800x2000		
	4 power modules	5 power modules	6 power modules		
	2400 kvar	3000 kvar	3600 kvar		
	3800x800x2000	4600x800x2000	5400x800x2000		
	4 power modules	5 power modules	6 power modules		
	2400 kvar	3000 kvar	3600 kvar		
	3800x800x2000	4600x800x2000	5400x800x2000		
	4 power modules	5 power modules	6 power modules		
	2400 kvar	3000 kvar	3600 kvar		
	3800x800x2000	4600x800x2000	5400x800x2000		
	4 power modules	5 power modules	6 power modules		
	2400 kvar	3000 kvar	3600 kvar		
	3800x800x2000	4600x800x2000	5400x800x2000		
	4 power modules	5 power modules	6 power modules		
	2400 kvar	3000 kvar	3600 kvar		
	3800x800x2000	4600x800x2000	5400x800x2000		
	4 power modules	5 power modules	6 power modules		
	2400 kvar	3000 kvar	3600 kvar		
	3800x800x2000	4600x800x2000	5400x800x2000		
	4 power modules	5 power modules	6 power modules		
	2400 kvar	3000 kvar	3600 kvar		
	3800x800x2000	4600x800x2000	5400x800x2000		
	4 power modules	5 power modules	6 power modules		
	2400 kvar	3000 kvar	3600 kvar		
	3800x800x2000	4600x800x2000	5400x800x2000		
	4 power modules	5 power modules	6 power modules		
	2400 kvar	3000 kvar	3600 kvar		
	3800x800x2000	4600x800x2000	5400x800x2000		
	4 power modules	5 power modules	6 power modules		
	2400 kvar	3000 kvar	3600 kvar		
	3800x800x2000	4600x800x2000	5400x800x2000		
	4 power modules	5 power modules	6 power modules		
	2400 kvar	3000 kvar	3600 kvar		
	3800x800x2000	4600x800x2000	5400x800x2000		
	4 power modules	5 power modules	6 power modules		
	2400 kvar	3000 kvar	3600 kvar		
	3800x800x2000	4600x800x2000	5400x800x2000		
	4 power modules	5 power modules	6 power modules		
	2400 kvar	3000 kvar	3600 kvar		
	3800x800x2000	4600x800x2000	5400x800x2000		
	4 power modules	5 power modules	6 power modules		
	2400 kvar	3000 kvar	3600 kvar		
	3800x800x2000	4600x800x2000	5400x800x2000		
	4 power modules	5 power modules	6 power modules		
	2400 kvar	3000 kvar	3600 kvar		
	3800x800x2000	4600x800x2000	5400x800x2000		
	4 power modules	5 power modules	6 power modules		
	2400 kvar	3000 kvar	3600 kvar		
	3800x800x2000	4600x800x2000	5400x800x2000		
	4 power modules	5 power modules	6 power modules		
	2400 kvar	3000 kvar	3600 kvar		
	3800x800x2000	4600x800x2000	5400x800x2000		
	4 power modules	5 power modules	6 power modules		
	2400 kvar	3000 kvar	3600 kvar		
	3800x800x2000	4600x800x2000	5400x800x2000		
	4 power modules	5 power modules	6 power modules		
	2400 kvar	3000 kvar	3600 kvar		
	3800x800x2000	4600x800x2000	5400x800x2000		
	4 power modules	5 power modules	6 power modules		
	2400 kvar	3000 kvar	3600 kvar		
	3800x800x2000	4600x800x2000	5400x800x2000		
	4 power modules	5 power modules	6 power modules		
	2400 kvar	3000 kvar	3600 kvar		
	3800x800x2000	4600x800x2000	5400x800x2000		
	4 power modules	5 power modules	6 power modules		
	2400 kvar	3000 kvar	3600 kvar		
	3800x800x2000	4600x800x2000	5400x800x2000		
	4 power modules	5 power modules	6 power modules		
	2400 kvar	3000 kvar	3600 kvar		
	3800x800x2000	4600x800x2000	5400x800x2000		
	4 power modules	5 power modules	6 power modules		
	2400 kvar	3000 kvar	3600 kvar		
	3800x800x2000	4600x800x2000	5400x800x2000		
	4 power modules	5 power modules	6 power modules		
	2400 kvar	3000 kvar	3600 kvar		
	3800x800x2000	4600x800x2000	5400x800x2000		
	4 power modules	5 power modules	6 power modules		
	2400 kvar	3000 kvar	3600 kvar		
	3800x800x2000	4600x800x2000	5400x800x2000		
	4 power modules	5 power modules	6 power modules		
	2400 kvar	3000 kvar	3600 kvar		
	3800x800x2000	4600x800x2000	5400x800x2000		
	4 power modules	5 power modules	6 power modules		
	2400 kvar	3000 kvar	3600 kvar		
	3800x800x2000	4600x800x2000	5400x800x2000		
	4 power modules	5 power modules	6 power modules		
	2400 kvar	3000 kvar	3600 kvar		
	3800x800x2000	4600x800x2000	5400x800x2000		
	4 power modules	5 power modules	6 power modules		
	2400 kvar	3000 kvar	3600 kvar		
	3800x800x2000	4600x800x2000	5400x800x2000		
	4 power modules	5 power modules	6 power modules		
	2400 kvar	3000 kvar	3600 kvar		
	3800x800x2000	4600x800x2000	5400x800x2000		
	4 power modules	5 power modules	6 power modules		
	2400 kvar	3000 kvar	3600 kvar		
	3800x800x2000	4600x800x2000	5400x800x2000		
	4 power modules	5 power modules	6 power modules		
	2400 kvar	3000 kvar	3600 kvar		
	3800x800x2000	4600x800x2000	5400x800x2000		
	4 power modules	5 power modules	6 power modules		
	2400 kvar	3000 kvar	3600 kvar		
	3800x800x2000	4600x800x2000	5400x800x2000		
	4 power modules	5 power modules	6 power modules		
	2400 kvar	3000 kvar	3600 kvar		
	3800x800x2000	4600x800x2000	5400x800x2000		
	4 power modules	5 power modules	6 power modules		
	2400 kvar	3000 kvar	3600 kvar		
	3800x800x2000	4600x800x2000	5400x800x2000		
	4 power modules	5 power modules	6 power modules		
	2400 kvar	3000 kvar	3600 kvar		
	3800x800x2000	4600x800x2000	5400x800x2000		
	4 power modules	5 power modules	6 power modules		
	2400 kvar	3000 kvar	3600 kvar		
	3800x800x2000	4600x800x2000	5400x800x2000		
	4 power modules	5 power modules	6 power modules		
	2400 kvar	3000 kvar	3600 kvar		
	3800x800x2000	4600x800x2000	5400x800x2000		
	4 power modules	5 power modules	6 power modules		
	2400 kvar	3000 kvar	3600 kvar		
	3800x800x2000	4600x800x2000	5400x800x2000		
	4 power modules	5 power modules	6 power modules		
	2400 kvar	3000 kvar	3600 kvar		
	3800x800x2000	4600x800x2000	5400x800x2000		
	4 power modules	5 power modules	6 power modules		
	2400 kvar	3000 kvar	3600 kvar		
	3800x800x2000	4600x800x2000	5400x800x2000		
	4 power modules	5 power modules	6 power modules		
	2400 kvar	3000 kvar	3600 kvar		
	3800x800x2000	4600x800x2000	5400x800x2000		
	4 power modules	5 power modules	6 power modules		
	2400 kvar	3000 kvar	3600 kvar		
	3800x800x2000	4600x800x2000	5400x800x2000		
	4 power modules	5 power modules	6 power modules		
	2400 kvar	3000 kvar	3600 kvar		
	3800x800x2000	4600x800x2000	5400x800x2000		
	4 power modules	5 power modules	6 power modules		
	2400 kvar	3000 kvar	3600 kvar		
	3800x800x2000	4600x800x2000	5400x800x2000		
	4 power modules	5 power modules	6 power modules		
	2400 kvar	3000 kvar	3600 kvar		
	3800x800x2000	4600x800x2000	5400x800x2000		
	4 power modules	5 power modules	6 power modules		
	2400 kvar	3000 kvar	3600 kvar		
	3800x800x2000	4600x800x2000	5400x800x2000		
	4 power modules	5 power modules	6 power modules		
	2400 kvar	3000 kvar	3600 kvar		
	3800x800x2000	4600x800x2000	5400x800x2000		
	4 power modules	5 power modules	6 power modules		
	2400 kvar	3000 kvar	3600 kvar		
	3800x800x2000	4600x800x2000	5400x800x2000		
	4 power modules	5 power modules	6 power modules		
	2400 kvar	3000 kvar	3600 kvar		
	3800x800x2000	4600x800x2000	5400x800x2000		
	4 power modules	5 power modules	6 power modules		
	2400 kvar	3000 kvar	3600 kvar		
	3800x800x200				

# MORE POWER, MORE VALUE.

GRIDCON® STATCOM – Dynamic reactive power compensation for the requirements of tomorrow.



## The right solution for every application

- Implementation of customer-specific solutions
- Modular system approach enables power scaling up to 7.2 Mvar
- Comprehensive communications interfaces (MODBUS, Profibus, IEC 61850) for exchanging information with the customer's on-site control system
- Compact design for high installation versatility (indoor, container)
- Combinations with passive systems are available for system optimization



## Maximum dependability and stability

- Redundancy at several levels (power module and individual IPU's)
- Faults with a duration of up to 250 msec do not cause the STATCOM to shut down (fault ride through)
- Full dynamics even in the event that the grid voltage has experienced a significant drop of up to 20% below the rated voltage (fault ride through)
- Compliance with the EMC requirements for industrial environments (EN 55011)



## Low life-cycle costs

- Extremely low losses keep energy consumption low and reduce the effort and expense needed for climate control
- The guaranteed availability of spare parts ensures a long service life for the devices
- Long operating duration free of interruptions thanks to high-quality power electronics components



## Easy to service and operate

- Comprehensive MR service: Commissioning, system updating including system consulting as well as a variety of training options in our in-house technology center for power electronics
- On-site support on short notice thanks to a global network of MR locations
- Integrated web server enables location-independent access to comprehensive status and service information
- Customer-specific operating interface over PLC-based system controller
- Simple service for individual components thanks to modular system approach
- Lasting flexibility thanks to independent parameterization for new or modified tasks

**Maschinenfabrik Reinhausen GmbH**

Falkensteinstrasse 8  
93059 Regensburg, Germany  
Phone: +49 941 4090-0  
Fax: +49 941 4090-7001  
E-mail: [info@reinhausen.com](mailto:info@reinhausen.com)

**LOW-VOLTAGE SOLUTIONS:**

**Maschinenfabrik Reinhausen GmbH**

Power Quality  
Wiebestr. 46  
10553 Berlin, Germany  
Phone: +49 30 330915-0  
Fax: +49 30 330915-25  
E-mail: [support.pq@reinhausen.com](mailto:support.pq@reinhausen.com)

**MEDIUM-VOLTAGE SOLUTIONS:**

**Maschinenfabrik Reinhausen GmbH**

Power Quality  
Alte Chaussee 73  
99097 Erfurt, Germany  
Phone: +49 361 30103-0  
Fax: +49 361 30103-20  
E-mail: [support.pq@reinhausen.com](mailto:support.pq@reinhausen.com)

[www.reinhausen.com](http://www.reinhausen.com)

Please note:

The data in our publications may differ from the data of the devices delivered. We reserve the right to make changes without notice.

IN5040625/00 EN – GRIDCON® STATCOM –  
F0339700 – 11/16 – uw  
©Maschinenfabrik Reinhausen GmbH 2016

THE POWER BEHIND POWER.

